



BATT-ID6B

Battery Back Up Box



Setup Guide

January 2025

Product Overview

This Battery Backup Box is a dedicated power supply solution for use with Contacta's ID-6B Hearing Loop Driver. It provides reliable backup power, safeguarding critical hearing loop operations in the event of power failure, by offering approximately 8 hours of operation. The device's battery is recharged automatically when connected to a power source.

Note:

- This product is not to be used as an emergency announcement system.
- There are no power indicators. The BATT-ID6 will continue to function normally during a power outage.

Components

1. 4 x Wall Plugs
2. 4 x M3 fixing screws
3. Fuse
4. Battery Back Up Box (BATT-ID6B)

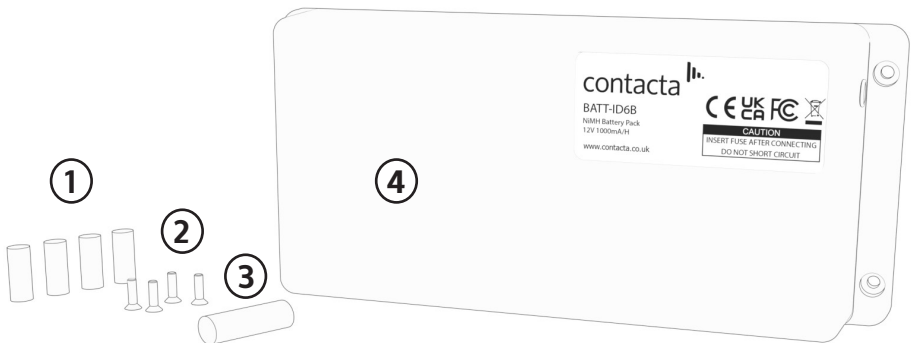

Connecting the BATT-ID6

1. Select an appropriate installation location for the Battery Back Up Box. Consider factors such as proximity to the ID-6B Hearing Loop Driver, accessibility for maintenance, and environmental conditions.
2. When the location is determined, secure the box in place firmly using the provided wall plugs and screws.

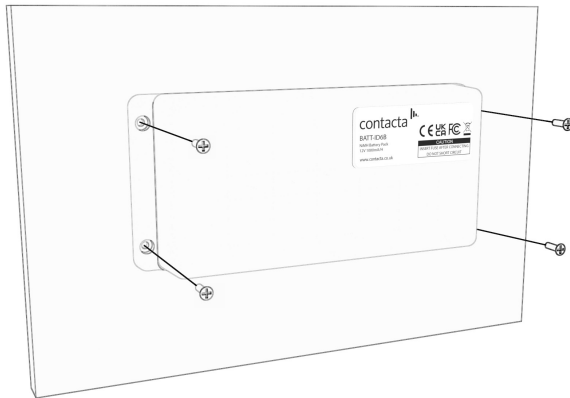

3. Connect the free ends of the cables to the "BATTERY BACKUP" port on the ID-6B Hearing Loop Driver, ensuring ensure correct polarity:
 - Red to positive
 - Black to negative
4. You may need a small screwdriver to loosen and tighten the cable connectors. [See diagram on the next page.] Connectors are bare wire connections, requiring the wire to be stripped prior to insertion.

Warning: Avoid short-circuiting the cables.

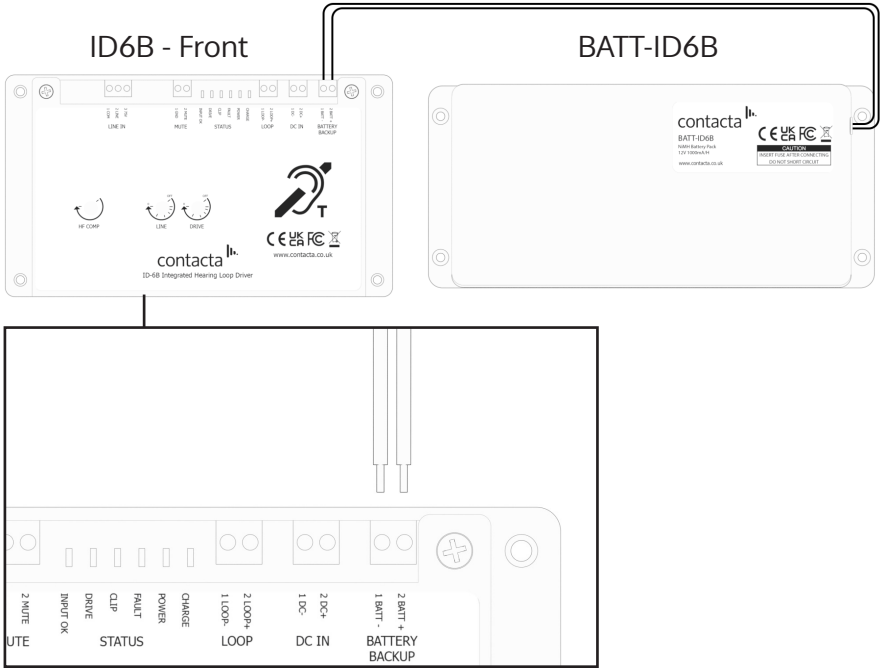

5. Take hold of the fuse included in the kit. To install it into the external fuse holder, twist the two sides of the holder to the left to bring them apart.

Note: The fuse is shipped disassembled for safety reasons.

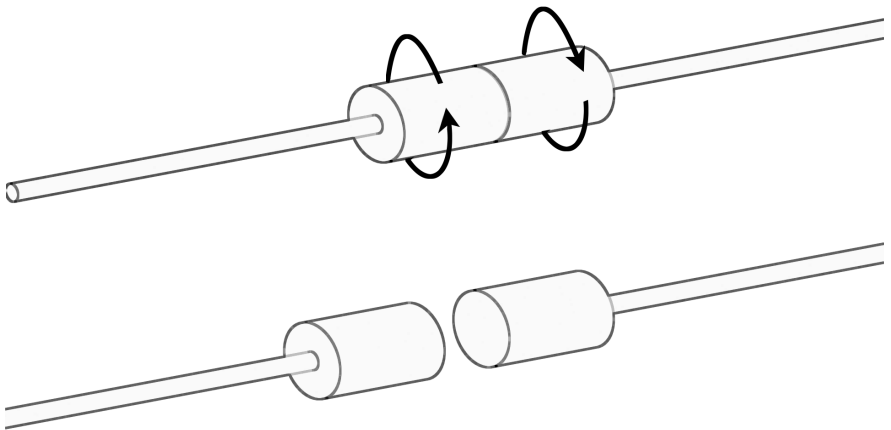

6. Place the fuse inside, then twist the two sides of the holder to the right to bring it together and secure the fuse in place.

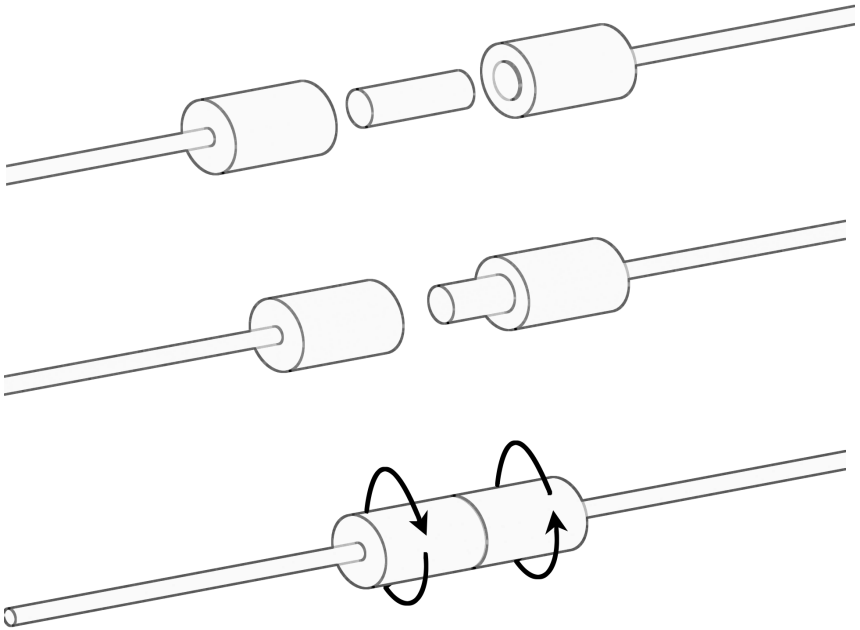

7. Battery box setup is now complete



Local dealer:

UK & ROW
+44 (0) 1732 223900
sales@contacta.co.uk

www.contacta.co.uk

US & Canada
+1 616 392 3400
info@contactainc.com

www.contactainc.com